

# The automatic greenhouse vent opener "Comfort-AERO-100"

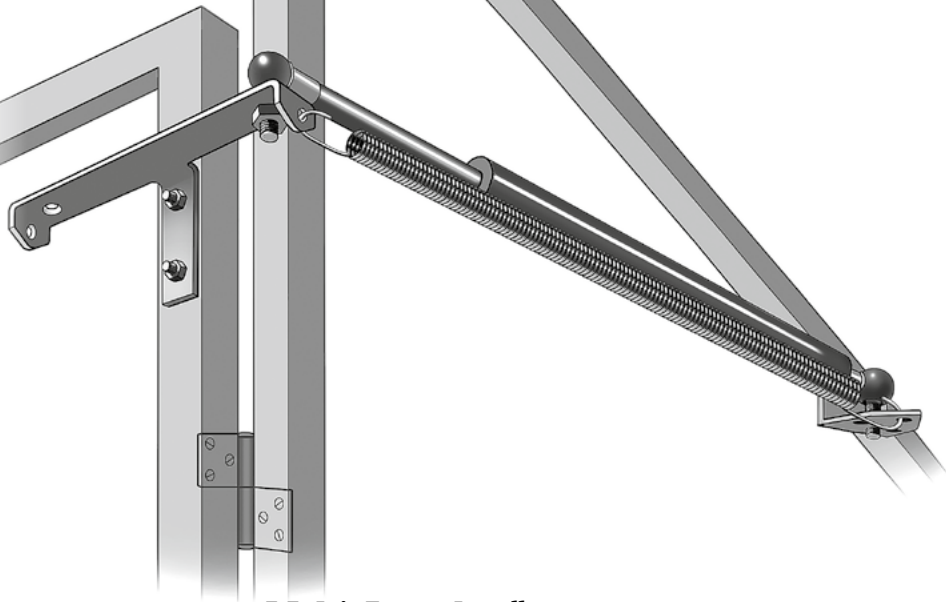

## PRODUCT'S DATA SHEET



### INSTALLATION AND USE INSTRUCTIONS

#### 1. Product's Purpose

For automatic opening and closing of the right- and left-sided doors, raising and swivel vent panes and transoms in home, farmer and industrial greenhouses (hereinafter – greenhouses) subject to the temperature of environment.

#### 2. Conditions of Use

- with the inserted spring: at temperatures from -25°C to +60°C;
- working temperatures range: from +5°C to +60°C;
- humidity: up to 98 per cent;
- power load (structure's weight, wind load) applied to the retractable rod: up to 100 kg

#### 3. Particular Features of «Comfort AERO-100» greenhouse vent actuator

The «Comfort AERO-100» greenhouse vent actuator surpasses all the existing analogous devices as for its technical features, the easiness of installation and use, its reliability and long useful life.

**3.1. The product is highly adapted to agricultural methods** which concern the formation of the thermal environment and takes into account the requirements of the agricultural cultures usually cultivated in Europe and in Scandinavia.

It works with the set temperature modes with adverse atmosphere impacts (wind, precipitation, temperature and air pressure variations).

#### 3.2. High Reliability Is Provided for by:

- the thermal actuator's steel body;
- the thick retractable rod;
- steel hinges (ball pivots);
- the mechanical pullback spring;
- steel universal supports.

The device is sensitive to temperature changes and allows to work in unfavorable meteorological conditions. Its useful life is long – up to 10 years.



#### 3.3. It is Easy to Install

This easiness is provided for by the features of the product's structure and by reliable universal supports which allow fixing the product to all the kinds of doors, vent panes and transoms. We did not include into the product's price the cost of the fixing systems (of the self-tapping screws, etc.) because in every specific case (subject to the thickness of the hothouse's arches, etc.), you need to choose fixtures of proper size (our recommendations can be found below).

**3.4. The High Speed of Action** when the temperature changes is provided for by the new formula of the gel with which the cylinder of the greenhouse vent actuator is filled. The black color of the cylinder's body provides for an elevated heat transfer from the environment to the cylinder's gel and back again. All these characteristics together provide for the rod's fast and smooth motion.

**3.5. It Allows Forced (Manual) Opening of the Door** which has been shut due to low temperature. The door which has been forcefully opened must get shut by itself with the action of a spring.







#### 4. Technical Characteristics

The characteristic's description	Size, range
The greenhouse vent actuator's steel cylinder: • Length: • Diameter:	• 350 mm • 22 mm
The thermal actuator's retractable rod: • Diameter: • Power stroke's length:	• 10 mm • From 0 mm to 100 mm subject to the loads and the way it has been installed
Exertion produced when the rod moves forward	100+20 kg
Steel hinges (ball pivots)	dismountable
Duration of the rod's forward motion when the cylinder's temperature changes from 20°C to 35°C.	Up to 40 minutes
Duration of the rod's inward motion when the cylinder's temperature changes from 35°C to 16°C.	

The characteristic's description	Size, range
The length of the advanced (visible) part of the rod at various cylinder temperatures: <ul style="list-style-type: none"> <li>• Less than 20°C:</li> <li>• From 20 to 23°C:</li> <li>• From 24 to 30°C:</li> <li>• 31°C and higher:</li> </ul>	<ul style="list-style-type: none"> <li>• 0-10 mm</li> <li>• 20-40 mm</li> <li>• 40-80 mm</li> <li>• 81-100 mm subject to the loads and the way it has been installed</li> </ul>
Steel pullback spring, zinc-coated	Working rate from 4 to 10 kg
Steel supports, shaped	3 mm thick
Flanged nut, zinc-coated	M8
The length of the thermal actuator cylinder together with the hinges: <ul style="list-style-type: none"> <li>• when the rod is fully out</li> <li>• when the rod is fully in</li> </ul>	<ul style="list-style-type: none"> <li>• 510 mm;</li> <li>• 410 mm.</li> </ul>
The weight of the assembled product	0,75 kg

**NOTE:** The acceptable deviation of the parameters sensible to the temperature is 10 per cent. Improvements and constructive changes which are not mentioned in these instructions are possible.

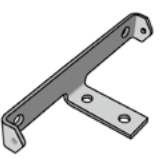
## 5. The Product's Supply as a Complete Plant

#	Name of the Accessory	Drawing	Quantity
1	Thermal actuator: a 350 mm long cylinder with a retractable rod which is 10 mm thick 		1
2	Steel hinges (ball pivots), thread M8, mounted on the thermal actuator 		2
3	Steel pullback spring, zinc-coated, with two grip hooks 		1
4	Steel flange nuts, zinc-coated, M8 		2
5	T-shaped support 		1
6	Triangular support 		1

#	Name of the Accessory	Drawing	Quantity
7	Product's data sheet		1
8	Shipping box		1

**NOTE:** Due to possible improvements, drawings, color and sizes can vary in what is actually supplied.

## 6. The Way of Preparation, the Installation and Assembly Procedure

### 6.1 The Tools Necessary for the Installation and Assembly

- 12 and 13 mm spanners – one of each;
- a screw-driver and a spanner in accordance with the chosen fixtures;
- a drill and a screw gun with a +1 mm bit for the chosen fixtures.

### 6.2 Preparation

Prior to the first installation and in the beginning of every usage season it is necessary to place the greenhouse vent actuator with the fixed spring without packaging for 4-8 hours in the environment with the temperature from +30 to +45°C until the rod is fully out by 80-100 mm.

This procedure of activation (decrystallization) of the gel inside the cylinder of the greenhouse vent actuator can last from 2 to 8 hours.

**IMPORTANT:** After the winter storage of the greenhouse vent actuator at negative temperatures it must be first of all kept in a room with the temperature of above +18°C for 24 hours prior to the activation procedure.

If after the installation the greenhouse vent actuator under the action of the spring at the temperatures below +20°C does not close completely this means that the decrystallization has not taken place completely or the greenhouse vent actuator has got cooled down to the temperatures of +20°C and lower without the spring fixed. Repeat actions from Paragraph 6.2.1 with the fixed spring.

Remember that you only can forcible pull out the rod of the greenhouse vent actuator. It can only be retracted by the action of the spring subject to the temperature of the gel inside the cylinder.

6.2.2. Choose the system necessary to fix the supports to the structure of the greenhouse.

We recommend using M5 countersunk head screws. The screws' length must take into account the following: the support's thickness of 3 mm + the thickness of the structure component (an arch or a door) + 5 to 8 mm of allowance. All in all, you will need 4 screws and 4 nuts of the necessary size. For example, if the greenhouse's components are 20 mm thick, you will need 4 M5 screws which are 30 mm long (Mx30) and 4 M5 nuts.

You should not take into account the polycarbonate's thickness since the screws must be set under it or pushing through the polycarbonate. The holes in the polycarbonate should be stopped with an aluminum adhesive tape or a sealer.

Self-tapping screws are not reliable enough at high loads and cannot be recommended.

### Greenhouse Vent Actuator's Installation Variants

It is fixed directly to the parts of the hothouse's frame. So that doors/vent panes on the frames which are not rigid do not warp, the main load should be applied in the middle of the door/vent pane. For this it is reasonable to install additional strips of board to which the support of the greenhouse vent actuator will be fixed. Subject to the frame's structure, other variants of installation are possible including swapping of supports' places, etc.



### FIXING TO THE DOOR



### FIXING TO THE VENT PANE

### FIXING TO THE VENT PANE WITH AN ADDITIONAL STRIP OF BOARD

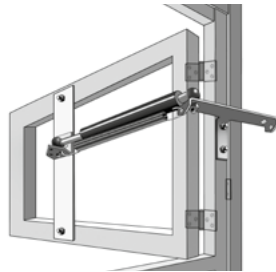

### FIXING TO A RAISING (VERTICAL) VENT PANE

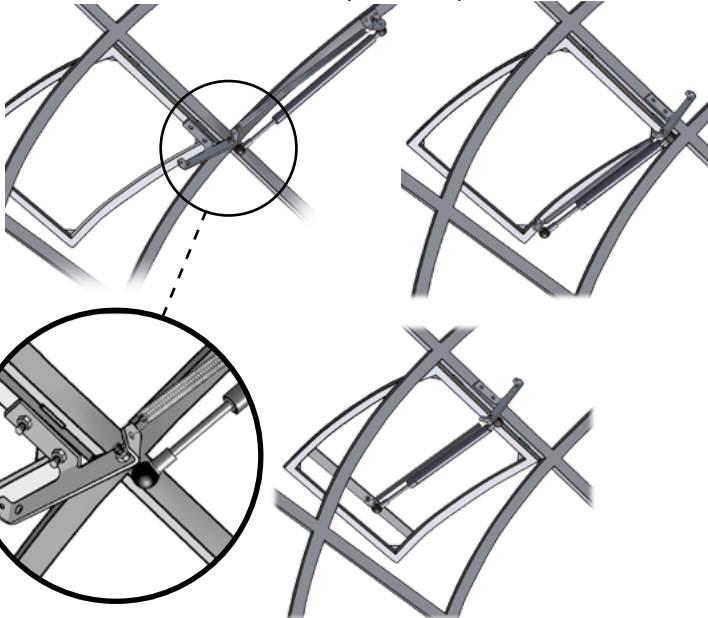

**NOTE:** The greenhouse vent actuator is fixed to raising vent panes/transoms in a way similar to that used for turning ones taking into account the construction's weight and size. To reduce wind load you should make the angle of opening as small as possible.

## 7. The Installation's Sequence.

- 7.1. The installation of the T-shaped support.
- 7.2. The installation of the triangular support.
- 7.3. The installation of the greenhouse vent actuator's cylinder.
- 7.4. The installation of the pullback spring.
- 7.5. Checking the ability to work and the installation of the limiter.

## 8. The Methods for Installation

### 8.1. The installation of the T-shaped support.

8.1.1. Before installation you should check if the door/vent pane/transom (hereinafter – the door) opens/closes easily. If it is necessary, the hinges should be oiled. You should remove the obstacles of the easy opening, check if the door tightly borders on the frame.

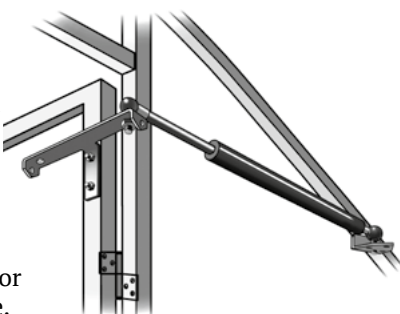

8.1.2. Open the door how it is necessary (the biggest angle of opening is no bigger than 90 degrees) and fix it in the motionless position by the means turned out to be at hand. To reduce the wind load the angle of opening of the door should be decreased, for example, to 80 degrees.

Manually pull out forcibly the movable rod (if it is necessary, the cylinder can be heated to 30° but not higher), so that its visible part (to the hinge's thread) is 100 mm long.

While the door is open and fixed in the desirable position and the greenhouse vent actuator's rod is pulled out by 100 mm, put the latter in the horizontal position perpendicular to the axis of rotation.

The T-shaped support should be applied to the door as close as possible to the axis of rotation (to provide for the greatest angle of opening). The T-shaped support should be so installed in height that the support's upper boarder is below the doorway by 25-100 mm (the values may be different subject to the greenhouse's construction).

After determining the height of the T-shaped support's fixing to the door and of the triangular support's fixing to the immobile part of the greenhouse's frame, mark there the position of the fixing holes.

8.1.3. Drill two T-shaped support's fixing holes. Install to the door the T-shaped support so that the screws' heads are below the polycarbonate. Tighten the fixtures. Lock the thread with the paint.

8.1.4. Install the retractable rod's hinge above in the opening of the T-shaped support and fix it from below with a flanged nut. Tighten the fixtures. Lock the thread with the paint.

### 8.2. The Installation of the Triangular Support

8.2.1. Fix the triangular support to the terminal part of the greenhouse vent actuator with the extended rod. Engage the flanged nut.

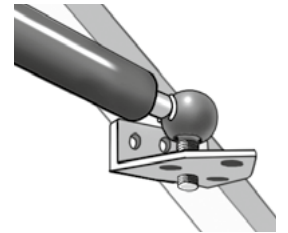

8.2.2. While the door is open and fixed in the desirable position and the greenhouse vent actuator's rod is pulled out by 100 mm, put the latter in the horizontal position perpendicular to the doorway and, after the determination of the triangular support's fixing position, drill the two holes.

**Attention!** Subject to the greenhouse's structure and the chosen fixtures, fixing with one or three screws is admissible.

Dismount from the greenhouse vent actuator and fix the triangular support in the manner described above.

### 8.3. Greenhouse Vent Actuator's Installation

Mount the hinge in the greenhouse vent actuator's terminal part in the triangular support's opening and fix it with a flanged nut. Execute the actions described in Paragraph 8.4. After a few automatic opening and closing cycles, if no necessity to shift the fixture to the next hole, tighten the fixtures. Lock the thread with the paint.

### 8.4. The Pullback Spring's Installation

Insert the pullback spring with its grip hooks in the supports' openings. Subject to the greenhouse structure's features, the spring tension can be increased by fixing it to the structure's part which is 20-40 mm away from the hole rather than to the triangular support. As a variant the spring can be shortened by a necessary number of coils.

### 8.5. Checking the Ability to Work and Installation of the Limiter

Free the door from the means which turned out to be at hand that fix it.

If the temperature of the environment (and of the gel in the cylinder) is below +23°C, the door closes by itself. The visible part of the retractable rod can be about 10 mm.

If the temperature is above +23°C, the door closes partially or remain open subject to the gel's temperature in the thermal actuator's cylinder.

**8.6. In Order to Extend Useful Life and to Avoid Breaking Down** we recommend to install the door opening limiters in the form of stops on the ground, cords (wires, chains, etc.) in order to reduce loads at the churly wind blasts. Subject to the area of the door or of the vent pane in the home greenhouse, at wind blasts of above 15 meters per second a shock load from 60 kg (the vent pane) to 120 kg (the door) may be created.

## 9. Use and Maintenance Recommendations

**9.1. Take off the greenhouse vent actuator** for the winter period so that it does not shut the door. The greenhouse must be penetrated by cold and aired, so it is better to take off the doors and the vent panes and to store them in the back office if it is not possible to open them and to fix them in the open position.

**9.2. When the season of use is over,** clean the greenhouse vent opener, corroded areas of rods and ball pivots should be cleaned with the solvent and lubricated with grease or technical oil. Balls inside the pivot should be lubricated with 1-2 drops of oil.

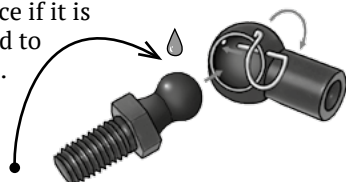

**9.3. Store the greenhouse vent opener with the inserted spring** at the temperatures of -25°C to +60°C and at the humidity of less than 98 per cent. Rain or snow cannot touch the thermal actuator.

**9.4. The corroded areas of the supports,** of the cylinder body and of the fixtures should be cleaned and retouched with the oil or alkyd paint. The corrosion of the paint job or of the zinc coating of the spring has no influence on the ability of the product to work.

**9.5. The T-shaped support** has been studied for the load of 140 kg. It bends with big wind loads and preserves the greenhouse vent actuator from being damaged. If you cannot straighten it (make it true), you can order a spare part there where you ordered your automatic greenhouse vent opener.

## 10. It is Strictly Forbidden

**10.1. To dismount the thermal actuator's cylinder.** The cylinder is pressurized. **It is dangerous.**

**10.2. To clean the movable rod with abrasive cleaners.**

**10.3. To warm up the thermal actuator to temperatures** above + 60°C (insert into hot water, at the gas-stove, at the heating radiator, with the hair dryer, etc.), freeze in the fridge, etc. Due to an abrupt and uneven warming/cooling of the cylinder and of the sealing rings the liquid may leak.

**10.4. To close the doors with the greenhouse vent actuator installed** on them forcibly and to push in the rod with an effort over 100 kg. Such an impact can make wind gusts of over 15 meters per second.

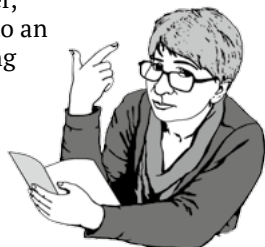

When the Ministry of Emergency Situations warns about unfavorable atmospheric conditions, you have to disconnect the thermal actuator from one of its supports to exclude an infringement of impact action directed to it.

**10.5. To block the doors, transoms and the vent panes** at the temperatures over +10°C and to prevent them from opening. Bolts, latches, etc. which hinder greenhouse vent actuator's normal work should be taken off.

The failure to meet the above requirements leads to damages and breaking down of the greenhouse vent actuator (the cylinder may get blown up, the gel liquid may leak, some parts may get deformed, etc.). These damages are not considered

to be guarantee events as well as damages due to unfavorable atmospheric conditions, fires, mechanical damages, etc.

We care about the quality of our products. All the products are checked for their ability to work and liquid tightness under elevated conditions of stress: the flaws in the sealers and in the whole product which cause liquid leaks are excluded.

## 11. Warranty Commitments

**11.1. The manufacturer guarantees** that its product conforms to its declared characteristics if the rules of its installation (assembling), use and storage as well as its limits and the requirements stated in these instructions are observed.

**11.2. The warranty term** of this product is 12 months from the moment of its selling in a shop.

**11.3. This warranty is not extended** to the paint job or to the product on the whole which has been damaged during transport or use for the failure to meet the requirements of these instructions.

## 12. Warranty Conditions

**12.1. The manufacturer provides** for elimination of the shortcomings (defects) of the product for whose appearance he is to blame.

**12.2. The manufacturer/the vendor does not fulfill any warranty commitments** and provide any warranty repair (a substitution) of the product neither returns any money in the following cases:

a) if the rules and conditions of the use and installation of the product which are described in these instructions have not been observed;

b) if the product bears witness of somebody else's intervention;

c) if the defect is due to the action of force majeure, due to an accident, the intended or careless actions of the consumer or of the third persons. During the season of use, subject to the conditions of use, the user must himself foresee all kinds of threats and take steps towards their prevention.

**12.3. This warranty's term is over in 12 months** from the moment of acquisition even if the product for some reason has not been used in this period.

## 13. Warranty Certificate

Automatic greenhouse vent opener "Comfort AERO-100"	
Date of purchase	
Vendor: name, address	
Stamp/Seal The vendor's signature	

## 14. Service in Guarantee Cases

In guarantee cases, if the damages described above, are absent, during 12 months from the date of purchase the product may be replaced with a new one there where it was bought.



Manufactured with the order of the SIA "Weis A" Company which is the distributor in Scandinavian and Baltic countries.

**Registered Address:** Vienibas gatve 169A. Marupes nov., marupe Latvija, LV-2167

**Contacts:** +371 26518293 E-mail: info@weisa.lv [www.weisa.lv](http://www.weisa.lv)

## Produced by:

**Private Entrepreneur Vinogradov I. Yu. St. Petersburg, Russia**

Phone: +7 (812) 927-61-50; +7 (911) 289-89-25

Copyright: Vinogradov I. Yu. 2019 Revision